

**Operation and maintenance
instructions**

original instructions

GG 800 N

Hydraulic Excavator

Warning: Unsafe use of this machine may cause serious injury or death. Operation and maintenance personnel must read this manual before operating and maintaining this machine. This manual should be placed near the machine for timely reference and all personnel related with this machine should consult this manual regularly.

preface

Dear users,

Thank you for your trust and love for our factory products! The company produces series of agricultural small excavator is given priority to with excavation, lifting unloading operation auxiliary agricultural small excavator, design a compact structure, power matching, product stability is good, cost-effective, can meet the plain, hills, forest under different operating conditions of excavation and unloading requirements, also applies to brick factory, kiln, river, construction, dredging, road construction. It can reduce the physical labor of workers, speed up the construction progress, improve the level of mechanization, is the most ideal main force of farmland operations and small projects.

In order to make the user correctly grasp the knowledge of the use, adjustment, maintenance and maintenance of the machine, and give full play to the effect of the excavator, please read this operation and maintenance manual carefully, and earnestly implement the provisions in this operation and maintenance manual. For the use and maintenance of the supporting engine, refer to the Engine use instructions prepared by the supporting engine plant.

Operation part: the driver uses the technical reference of

the machine, during which the driver can guide the driver to use the correct program to check, start, operate and stop the machine. The operation technology outlined in the manual is a basis, and the driver acquired the machine and its functional knowledge can improve his own technology and skills.

Maintenance part: the user for the whole machine maintenance instructions. The specific maintenance measures of the machine are detailed in the Excavator Maintenance Catalogue. Users shall maintain the maintenance items according to the requirements and the different mechanical working time.

In extremely harsh, dusty or wet working conditions, according to the number of the operation of the machine.

In order to more intuitively show some structural features of the machine, some of the demonstration pictures in this manual are set to the structural perspective view, so the appearance will be different from the actual product. If the actual excavator mechanical structure and technical parameters change due to the technical improvement and are not shown in this manual, please consult the company for the latest product information of the product.

Before using or repairing the machine, the relevant

information shall be approved, and we may contact the company's technical service station if necessary. When purchasing the parts, please specify the factory date and number of the excavator.

As the company's product technology is constantly innovating, we reserve the right to explain and modify this manual.

If the actual product is different from the pictures in this manual, the actual object shall prevail.

Chapter I Safety precautions and safety identification

1.1, Safety precautions

General precautions

It is your responsibility to follow the relevant departmental safety codes and laws and to operate the inspection and maintain the machine as required by the manufacturer.

1.2 Safety identification tips

The following warning signs and safety signs are used.

1. Be sure to fully understand the correct location and content of the sign.
2. To ensure that the signs can be read properly, ensure that they are in the right position and always keep the signs clean. When cleaning signs, do not use organic solvents or gasoline, otherwise they will peel off.
3. There are other signs besides warning signs and safety signs. Treat the signs in the same way.
4. If the sign is damaged, lost or cannot be read properly, replace it with a new one. For details of

the sign part number, see this manual or actual sign and send the order to the factory.

Security identification location

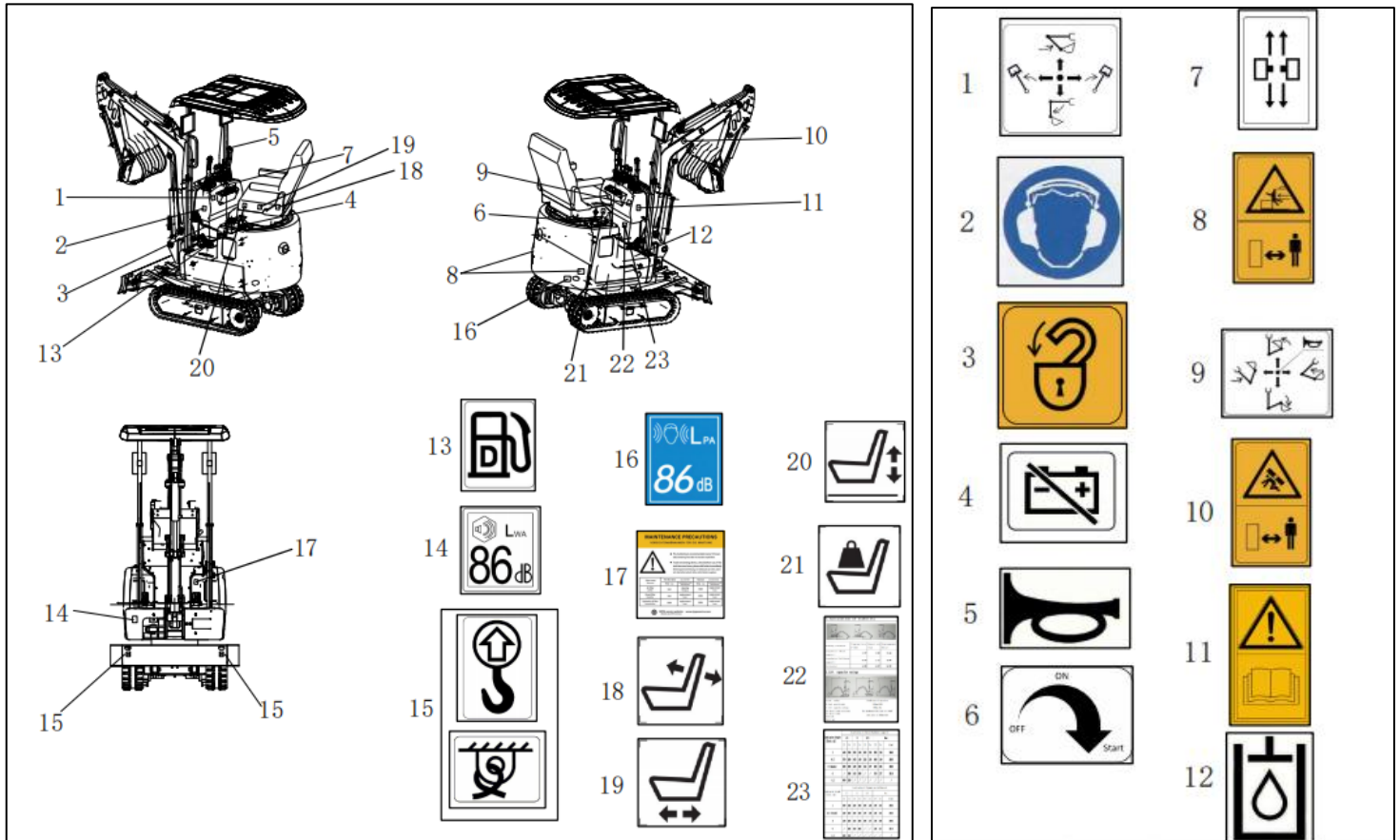

(1) Diagram of the excavator operation mode.

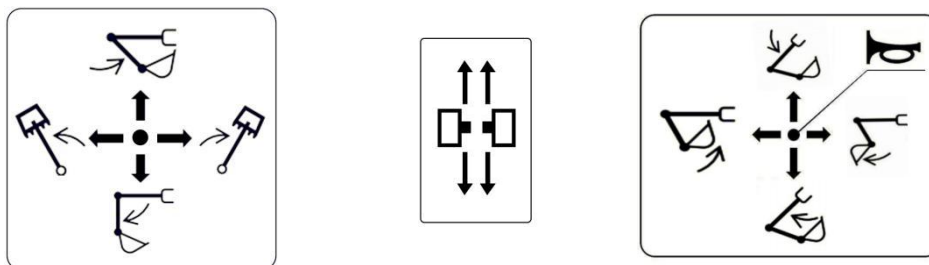

△ Carry out the basic operation of the excavator according to the above diagram. It is strictly

prohibited to operate the excavator according to the sign.

(2) Wear ear guards when operating the excavator.



△ With ear protection device warning.

(3) Put down the operation lock after operating the machine.



△ This position is the operation locking mechanism. After the operation machine is completed, drop the operation locking rod to ensure the driver's misoperation.

(4) Fuel oil filling port

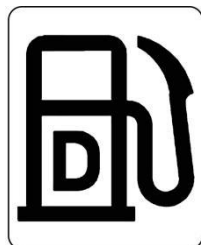

△ Fill fuel at the specified location.

△ Turn off the engine when filling the fuel, and the fuel filling should be kept away from all open fires.

(5) No one standing person at the lower end of the working device



△ It is strictly prohibited to stand within the area of the machine working device.

△ Do not damage or remove the mark from the machine.

(6) Notes for operation, inspection and maintenance



△ Read the manual before operation, maintenance, decomposition, assembly and transportation.

△ Be careful not to damage it and lose it.

(7) It is strictly prohibited to stand within the operation scope



△ It is strictly prohibited to stand in the operation.

△ Note the rotation radius of the machine.

(8) Pay attention to the machine running noise of 93dB

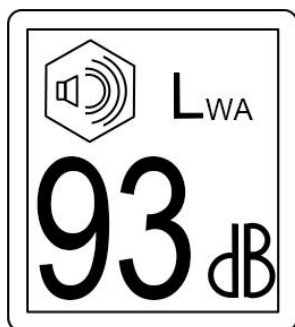

(9) Hoisting position sign drawing.

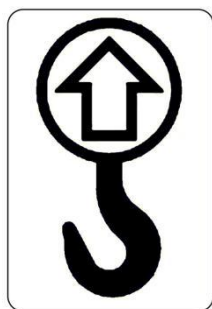

(10) Sign diagram of the bundled transport point.

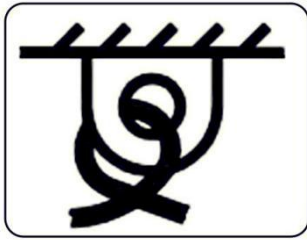

(11) Maintenance sticker:

MAINTENANCE PRECAUTIONS
VORSICHTSMAßNAHMEN FÜR DIE WARTUNG



- Pin, buttering is recommended every 10 hours
Stift, Buttering wird alle 10 Stunden empfohlen
- Track tensioning device, check before use, if the track becomes loose, please add butter immediately
Kettenspannvorrichtung, vor Gebrauch prüfen, wenn sich die Kette lockert, bitte sofort Butter zugeben

Filter name filtername	The first time		Normal	
	Time	Zeit	Time	Zeit
Air filter Luftfilter	50H	cleaning Reinigung	100H	replacement Ersatz
Diesel filter Dieselfilter	50H	replacement Ersatz	200H	replacement Ersatz
Hydraulic oil filter Hydraulikölfilter	100H	replacement Ersatz	300H	replacement Ersatz

(12) outage:

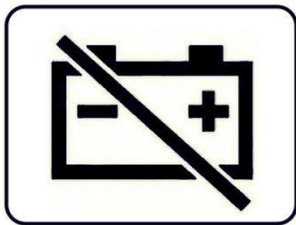

(13) Throttle control:



(14) Seat adjustment instructions:



Back adjustment, front and back adjustment, up and down adjustment.

(15) Start switch identification:

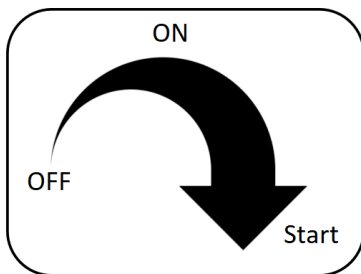

(16) Ear-side noise identification:



- ◆ the A-weighted emission sound pressure level at the operator's station is 86 dB(A).
- ◆ the uncertainties of noise emission values is 3.5 dB.

1.3 Safety information

safe rules

1. Only the trained and guided personnel can operate and maintain the machine.
2. Observe all safety rules, precautions and instructions when operating or maintaining on the machine.
3. Being in the influence of alcohol or drugs, can severely reduce / weaken the ability to safely operate or repair the machine, putting yourself and others present at risk.
4. When working with another operator or site traffic commander, make everyone understand all the gesture signals used.

If an exception is found

If any abnormality (voice, vibration, smell, incorrect instrument display, smoke, oil leakage, etc., or any abnormal display on the alarm device or monitor), report to the supervisor and necessary measures shall be taken. Do not operate the machine until the fault is corrected.

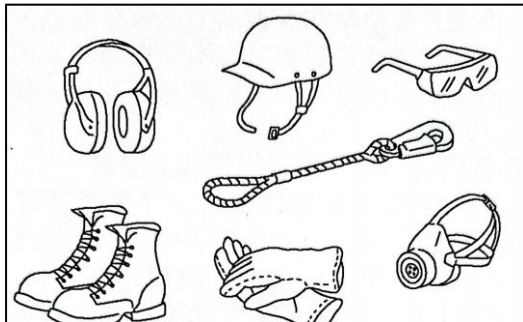

Work clothes and protective equipment for the operators

Do not wear loose clothes and accessories. They have hanging controls

Hazanger of rods or other protruding parts. If the hair is

too long, and it sticks out

The helmet is in danger of being entangled into the machine. So tie your hair up,

Be careful not to keep your hair hanging around the machine. Always wear a helmet and safety

All shoes. When operating or maintaining the machine, wear it if required

Safety glasses, masks, gloves, earplugs, and seat belts. in use
Before, check the normal function of all protection devices.

safety

1. Ensure that all shields and covers are in their proper place. If the cover and cover are damaged, repair them immediately.
2. Understand how to use the safety devices and use them correctly.
3. Do not remove any safety devices and keep them in good working condition.

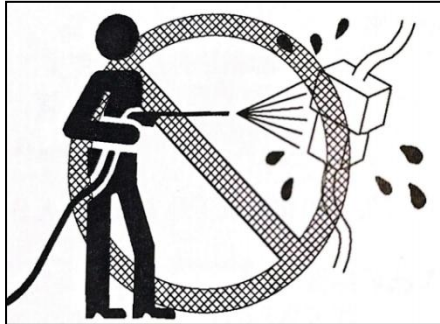

Keep the machine clean

1. If the electrical system enters the water, there is a risk of failure or failure. no
Rinse the electrical system (sensors, connectors) with water or steam.
2. If the machine is checked and maintained with mud or oil pollution, it

is slippery

The danger of falling and falling or the danger of dirt entering the eye.

2. Keep the machine clean at all times. Keep the operating position clean when in

When driving, be sure to remove the mud and oil from the sole. If in the sole

Operating the pedal with mud or oil, the foot will slip and cause serious problems malfunction.

Leave the operator seat when locked

1. Before standing up from the operator seat (when the front or top window is opened or closed, or installed, or when the seat is adjusted), fully lower the working device to the ground and bring the operating lock to the locked position. Then turn off the engine. If no lock lock is accidentally touched, there is a risk of sudden machine movement and causing serious injury or machine damage.
2. When leaving the machine, be sure to drop the working device completely to the ground, pull the operation lock firmly to the locked position, and then close the engine. Lock all the equipment with the key and take the key off and place it in the specified position.

3. Remember the distribution map of the safety devices.

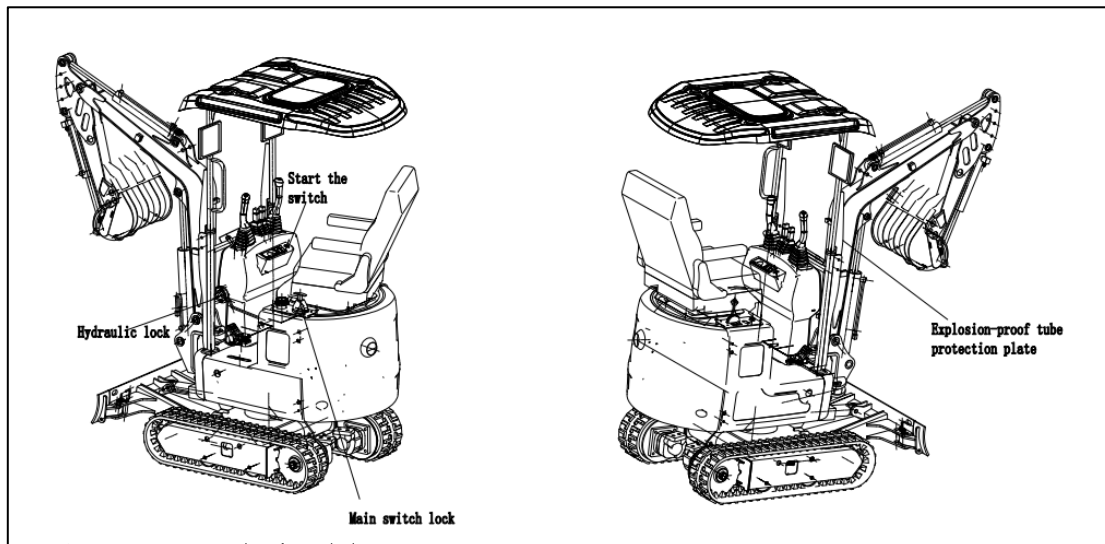

Armor and ladder

To prevent personnel injuries caused by slipping or falling from the machine, follow the following requirements.

1. When on and down the machine, use the handrails and steps marked in the picture.
2. To ensure safety, face the machine and keep three points (two feet, one hand or two hands and one foot) in contact with the handrail and steps (including track boards) to support yourself.
3. Do not grasp the control lever when going on and off the machine.
4. Do not climb onto the hood or cover without a slip pad.
5. Check the handrails and steps (including track plates) before the upper and lower machines. If the handrails or steps (including track plates) have oil, grease, or mud, wipe them off immediately. To keep these parts clean. If damaged, repair them and tighten the loose bolts.
6. Do not lift up or drop the machine while holding a tool in your hand.

Up and down the machine

1. Do not jump on, or off, the machine. When the machine moves, do not go up or down the machine.

2. If the machine starts moving when there is no operator, do not jump on the machine and try to stop the machine.

No one is allowed on the attachment

Do not let anyone sit on a bucket, grab, clam shell grab, or other attachment because there is a risk of falling or causing serious injury.

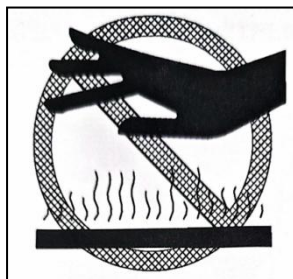
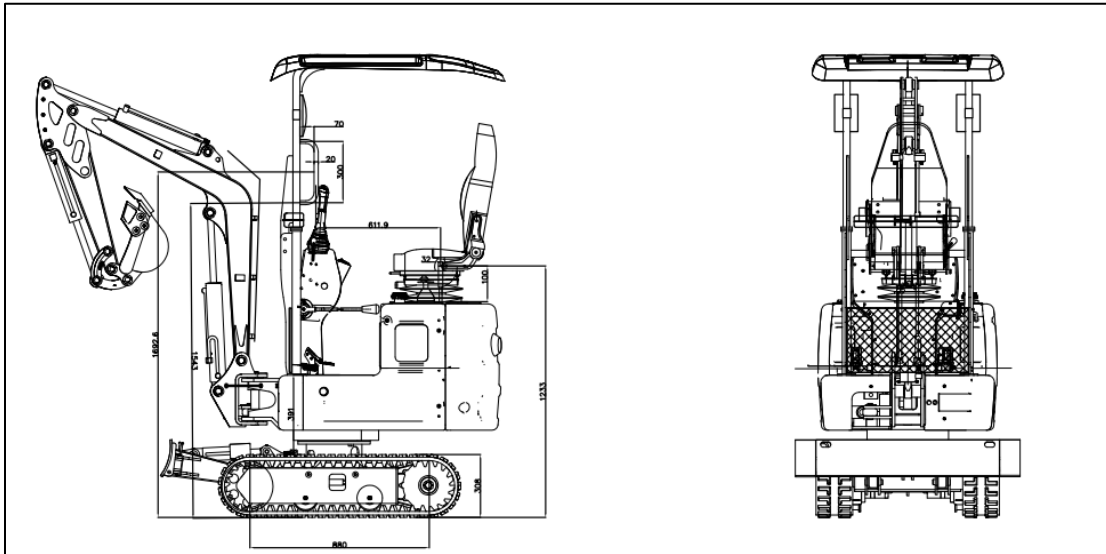

Thermal coolant

1. When checking or discharging the coolant, to prevent hot water or steam spray caused by hot Injury, before starting the operation, wait for the water to cool until you can touch the radiator cover by hand

The temperature of. Even if the coolant has cooled, before the radiator cover is removed

Slowly release the cover to drain the internal pressure of the radiator.

hot oil

1. When inspecting or discharging oil, to prevent oil from being ejected or due to contact with heat The parts cause burns, wait for the oil to cool down before hand

Touch the temperature of the cover or the plug. Even if the oil has cooled, remove the cover or plug Before, also slowly release the cover or plug to remove the internal pressure.

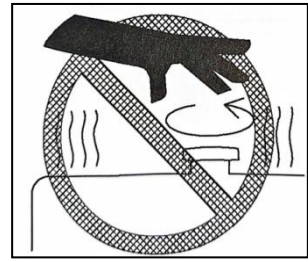

Fire and explosion-proof

Fire caused by fuel or engine oil

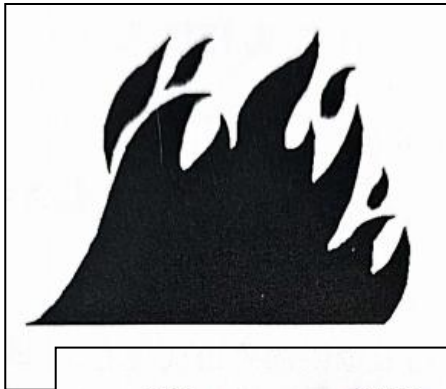

Fuel oil, oil, antifreeze and window detergent are very flammable and dangerous.

To prevent fire, the following regulations must be observed:

1. Do not smoke or use any open flame near the fuel or engine oil.
2. Turn off the engine before refueling.



3. Do not leave the machine when adding fuel and oil. Fuel and machine tank cover
Tighten firmly.
4. Do not allow fuel to spill on overheated surfaces or components of the electrical system.
5. Fuel up or store oil in a well-ventilated place.
6. The engine oil or fuel oil should be kept in a designated place, not without permission
get into.
7. After adding fuel or oil, wipe away the spilled fuel or oil. When in

When grinding or welding on the lower car body, before the start With flammable materials moved to a safe place.

8. When washing parts with oil, use non-flammable oil, diesel and gasoline

Easy to catch fire, so do not use them.

9. Place oily rags or other flammable materials into a safety container to keep working

Site safety.

10 Do not weld or cut the torch for tubes containing flammable liquids.

Fire is caused by the accumulation of flammable

materials.

Remove dry blades, pieces of wood, paper, dust, or other flammable materials accumulated in or stuck around the engine, exhaust manifold, silencers, battery, or inside the hood.

Short circuit of the electrical system can cause a fire.

1. Keep the wire joints clean and firmly fixed.
2. Check whether the wires are loose or damaged every day. Tighten loose joints or wire clips, and repair or replace damaged wires.

Fire caused by the hydraulic line.

Check that all hoses and tube clips, shields and cushions are firmly in place.

If loose, it will vibrate and rub with other parts during the operation, leading to hose damage, high pressure oil ejection, causing fire hazard or serious injury.

Explosion caused by the lighting equipment.

1. When checking fuel oil, oil, battery electrolyte, window detergent or coolant, use lighting with explosion-proof performance. If this lighting equipment is not used, there will be a risk of serious injury caused by explosion.
2. When the power supply of the machine is used for lighting, follow the provisions in this manual.

Action in case of a fire

In case of a fire, dial the following instructions to leave the machine quickly.

1. Turn the start switch to the OFF and turn off the engine.
2. Use the handrails and steps to leave the machine.



Prevent falling, scattering and intrusions

When falling, scattered and introjects into dangerous workers entering the cab

As the site, consider the operation situation, and install the necessary cover to protect the operator.

1. When dismantled or broken, the front shield should be installed and placed on the front glass

Post a transparent cellophane.

3. FOPS is installed when working in a mine or stone yard (fall

Protection device) and front cover, and paste transparent cellophane on the front glass.

4. When doing the above operations, closing the front window. In addition, to ensure that other personnel

Outside the falling hazard area and maintain a proper safe distance.

5. The above mentioned is for typical working conditions, according to the operation of the site,

Additional shields may be required. Please contact the factory service personnel in advance.



Attachment installation

1. When installing selected items or accessories, there are safety or legal problems, so please contact our service staff in advance.
2. Any injury, accident or product failure due to the use of unapproved accessories or parts is not related to the plant.
3. When installing and using the selected accessories, read the instruction manual for the accessories and the general instructions on the accessories in this manual.

The combination of accessories

Depending on a type or combination of working devices, there is a risk of working devices hitting the cab or other parts of the machine. When using unfamiliar workers, check for the danger of interaction and operate carefully.

Unapproved modifications

Any modification not approved by the plant can be hazardous. Before the modification, to contact with the professional technical service personnel.

1. The factory will not be held liable without the approval of the plant.

Safety of the work site

Before starting operations, thoroughly check the work area for any Abnormal and hazardous situation.

1. When operating near combustibile materials such as thatched roofs, dry leaves, or hay, There is a danger of fire, so be careful when operating.

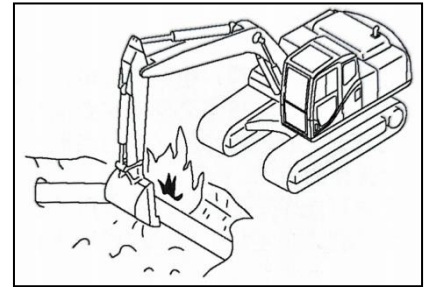

2. Check the terrain and conditions of the work site ground and identify the safest operator law. Do not operate in places at danger of landslides or rockfall.
3. If there is a water pipe, pipe or high voltage wire buried under the work site, with each Utilities should contact and mark their locations, and be careful not to break up or damage any lines.
4. Take the necessary measures to prevent any unauthorized personnel from entering the work area.
5. When working on the highway, arrange signal personnel and install fences to ensure the safety of traffic and pedestrians.
6. When walking or operating in shallow water or on soft ground, check the type and condition of the rock beds and the depth and velocity of the water before the operation.

Working on the loose ground

1. Avoid walking or operating machines near the edges of cliffs, shoulders and deep canals. In such areas, the ground is soft, and if the ground collapses under the weight or vibration of the machine, there is a danger of it falling or tipping over. Remember, these places turn after heavy rain, blasting, or after an earthquake.

2. When working on the embankment or near the dug trench, there is a danger of soil caused by the weight and vibration of the machine. Take steps to secure the ground and prevent the machine from tipping or falling.

Ensure good visibility

To ensure safe operation or walking, check the area around the machine for people or obstacles and check the condition of the work site. Follow the following steps.

1. When working in a dark place, turn on the working lights and headlights installed on the machine, and set up auxiliary lighting in the working area when necessary.
2. If the sight is not good, if there is fog, snow, rain or dust, to stop the operation.

Ventilation of the enclosed areas

The engine exhaust can be fatal.

1. If the engine must be started in an enclosed area, or when handling fuel, cleaning oil or paint, open the doors and Windows to prevent gas poisoning to ensure adequate ventilation.

Signals and gestures of signalmen

1. Set up signs on the shoulder or soft ground. If the sight is not good, arrange a signalman if necessary. The operator shall pay special attention to the signs and take command from the signalman.
2. Can only be sent by one signaler.
3. Make sure that all workers know all the signals and gestures before starting work. Cab emergency exit

Prevention of the asbestos dust hazard

If inhaling asbestos dust in the air can cause lung cancer. When in the workplace

There is a risk of inhaling asbestos when engaging in demolition operations or disposal of industrial wastes. one

The following rules must be observed.

1. When cleaning, to spray water to reduce the dust, do not use compressed air cleaning.
2. If it may contain asbestos dust in the air, it must be held in the upper limelight position

As a machine, all personnel should use qualified dust filter masks.
3. During the operation process, other personnel are not allowed to approach.

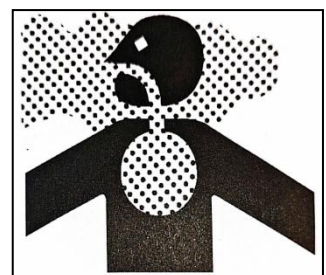

4. Compliance with work site regulations, regulations and environmental standards.

Chapter 2 Preparation before work

Before operation, the vehicle condition and the operation area should be fully understood to ensure safety.

2.1 Inspection of fuel oil quantity

Fuel oil quantity inspection

Before operation, the fuel capacity of the vehicle should be checked. When the fuel is insufficient, the fuel should be replenished in time to avoid entering the air because the fuel is exhausted, and the machine may be unable to catch fire after refueling again. See Section 9.5 for no-fire disposal methods.

Due to the large differences in different climate of the machine, the areas with low temperature in winter must choose the diesel suitable for the local temperature, such as the lowest temperature of -20 degrees, the diesel needs to choose -30 # diesel, otherwise the diesel freezing will occur, and it is difficult to start or unable to start the machine.

2.2 Inspection of track tension

Before operation, the track tension should be checked. If the track is too loose, the wrench should be adjusted to tighten the track (as shown in the following figure below). The adjustment mouth forms of different models are slightly different, but the position is roughly the same, and the physical object shall prevail.

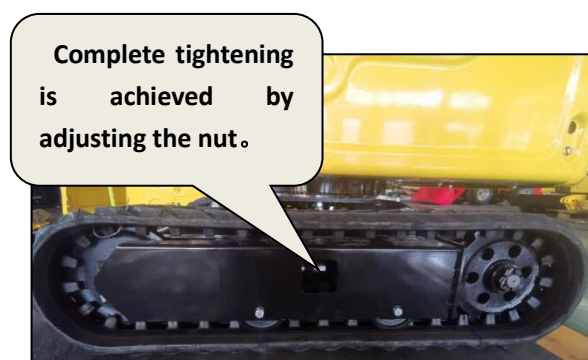

The track is turning when too loose and turning around. When walking unilaterally, the track is easy to fall off. Once the track falls off, it is difficult to install.

2.3 Hydraulic oil and oil quantity inspection

Check the hydraulic oil level before operation, hydraulic oil level is too low in the body tilt tank side, will cause oil pump suction oil and the vehicle without any action (the action should be immediately stalled, the oil pump continue to work with hydraulic pump serious wear and even damage) need to add hydraulic oil or the body flat, if no hydraulic oil or unable to pad the body, for part of the mechanical operating system model can try to break the rotating stem, push the big arm, arm to the high side of the body, and then start the machine, if there is action, priority to adjust the car to the level, and then supplement the hydraulic oil.

Oil inspection

The hydraulic oil used by the excavator is 46 # anti-wear hydraulic oil. Due to the large differences in different climates in the use areas, too low or too high temperature will affect the viscosity of the hydraulic oil, resulting in insufficient or abnormal pressure of the system, and even accelerate the wear of the oil pump. Areas with special climate (too cold or overheating) should have the local climate conditions to choose the hydraulic oil suitable for the local temperature.

2.4 Oil and oil quantity inspection

Check the engine oil before operation, check whether the oil is sufficient (because the machine work climbing, downhill, tilt, such as various situations, so the oil should be close to the oil ruler limit position, prevent the pump pumping oil), insufficient to timely supplement, (oil as the engine work slowly, so regularly check the oil quantity is necessary) otherwise it will lead to engine transition wear or pull cylinder, due to the lack of oil pull cylinder or other problems, the engine manufacturer shall not be warranty.

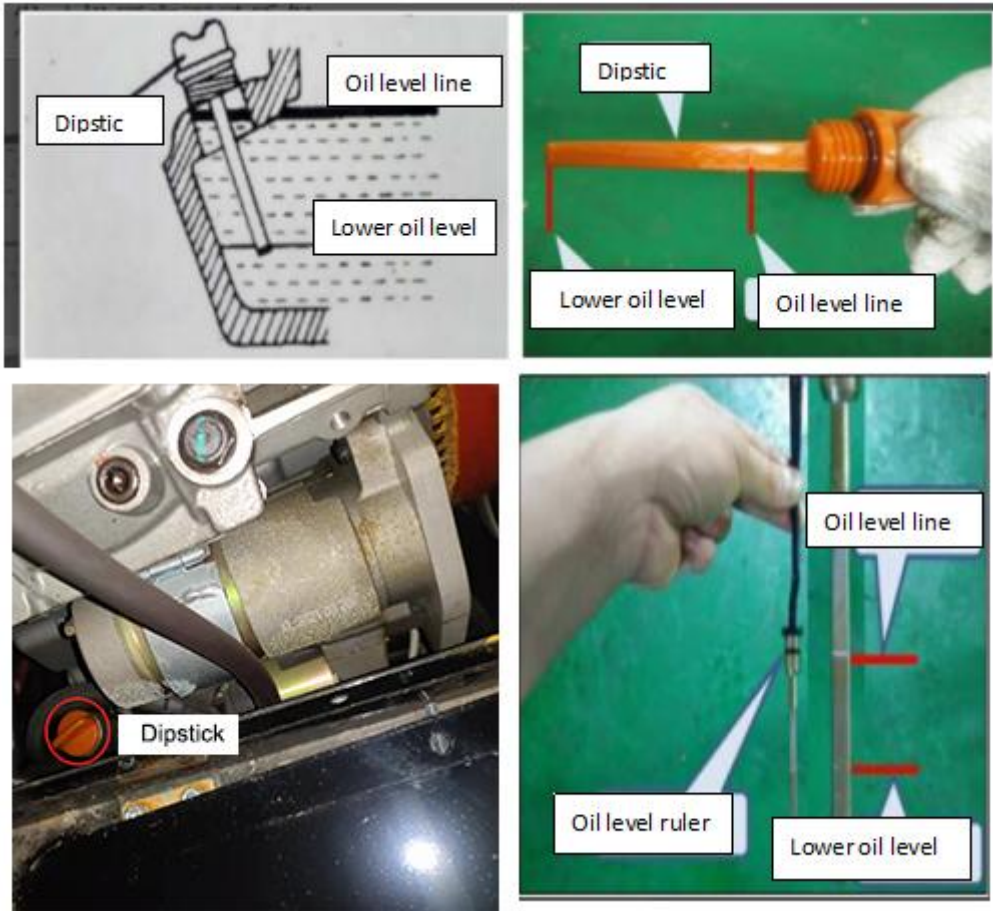

2.5 Check of the lubrication points

Each lubrication point of the excavator should be checked before operation. Generally, grease should be added to each lubrication point every 8 hours. The refueling quantity should be sufficient, and the refueling frequency should be increased when the working conditions are bad.

2.6 Check the tightness of the fixing bolts for important components

Important components include rotary support, rotary motor and engine. Before operation, check the fixing bolts of these parts for loosening phenomenon. If there are loose bolts, they must be tightened immediately. If necessary, you can consult the manufacturer. If the loose bolts are not checked or tightened, it may cause serious problems such as gear interruption of rotary support and rotary motor, engine loss, damage of wind ring and water tank.

2.7 Oil leakage inspection

Before operation, you should observe around the car and check the chassis to check whether the excavator has oil leakage. If so, it should be fixed or repaired in time.

2.8 Inspection of the operation area

Check the terrain and ground conditions of the operation area, and check during indoor operation

Check the building structure and take safety measures if necessary.

Avoid things such as ditches, underground pipelines, trees, cliffs, and racks

Empty wires or dangerous areas such as rockfall or landslide.

Check the buried gas pipes, water pipes and power cables with the administrators

The position of. If there is a necessary consultation and determination must be adopted to ensure safety

Full range of specific safety measures.

Be sure to consider the safety of pedestrians and vehicles when working on the road,

Use the signalman and / or signal. Isolated operation area, unauthorized personnel

Do not enter.

When working in the water or crossing a shallow stream, the water depth should be examined in advance

Whether the ground is solid and the water flow speed.



2.9 Check the strength of the bridge

When on the bridge or structure.

If the strength is insufficient, the bridge or the structure should be strengthened.

2.10 Keep the machine clean at all times

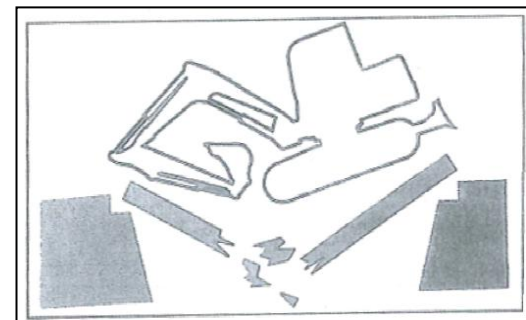

1. Wipe off lubricating oil, grease, soil, snow or ice to prevent this

The skid caused an accident.

2. Remove all loose objects and unnecessary devices in the machine.

3. Remove the dust, lubricating oil or grease from the engine part to prevent it breaking out of fire.

4. Clean the operator seat and clear the machine of any unnecessary conditions body.



2.11 Daily inspection and maintenance

Abnormal condition or damage not identified (or not repaired) of the machine will cause malfunction.

Before operation, please conduct the specified inspection and repair immediately if necessary.

If there is an accident or engine failure, immediately stop according to the shutdown procedure and park the machine until the fault is fixed.

Chapter 3: The Safe Operation of the Machine

3.1 Start the engine

If a warning sign is hung on the operating device control lever, Do not start the engine or contact the control lever.

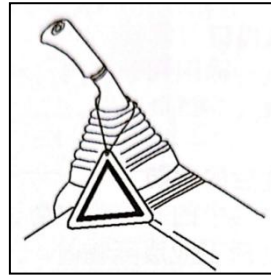

3.2 Preparation before startup

Turn on the main power switch before starting the engine, turn the start switch, press the decompression switch after the engine speed reaches, release the start key immediately after the engine fire, and confirm whether the key plays back.

It is strictly prohibited to turn the key again after the engine starts. This operation will damage the starter motor and the engine flywheel gear, or even destroy the starter shell and burn the starter coil. In addition, excessive turning of the fire key will cause the key to not rebound. After the engine starts, the starting gear of the engine cannot be separated from the engine. Under the case of high speed driving of the engine, the current in the starter will rise rapidly, leading to the burning of the coil.

Start the key itself with dust, can effectively avoid dust water and other substances into the key, once there are impurities such as water into the key, can lead to lock core stuck not back or internal short circuit, damage the starter, so on rainy days or wet, outside dust more environment to avoid long time out the key parking, if need parking must be the key of protective measures.

Special note: the diesel engine still fails to start after 10 seconds, please wait for 15 seconds to start again (the continuous starting power opportunity for a long time leads to a large amount of battery power consumption, and the starter may be burned out). The damage of the starter caused by the above reasons.

Start method in winter: the model has the preheating function. When the weather is too cold, the key switch must be turned in reverse and stored for 8~10 seconds (not for a long time, otherwise the battery will cause power loss), and then start normally

Move the engine.

After starting the machine, the power master switch and key 1 gear are turned on, otherwise the battery cannot be charged.

After starting the engine, perform the following operations and inspections in places where there are no personnel or obstruction. If any fault is found, shut down according to the program and report the fault.

1. Preheat the engine and hydraulic oil for 5-10 minutes.
2. Check whether the instruments and alarm devices are working normally.
3. Check for any noise.
4. Test the engine speed control.
5. Do not use either ether or starter fluid on the engine. The starting fluid can cause an explosion and serious injury or death.
6. Preheat the engine and the hydraulic oil. If the control lever is operated without preheating, the machine will not react or move quickly or appropriately, causing an accident.

3.3 Operation

Check after starting the engine

When checked, move the machine to a wide area without obstacles and operate slowly. No one is allowed to approach the machine.

1. Be sure to fasten your seat belt.
2. Check the machine movement for consistent with the display on the control mode card. If not, immediately use the correct control mode card more
3. Check the operation of the instrument and equipment, and check the operation of the bucket, bucket bar, boom, walking system, swing system and steering system.
4. Check the sound, vibration, heating, smell or instrument for any leakage of oil or fuel.

Workstation setup

Get on

1. Get on the car from the left side, and the operator will pull the operation lock upward;
2. Move the operation lock upward to the end position.
3. Put your hand on the designated position of the handle and push off the steps to get on the bus;
4. Turn and sit in the seat operating position.

Adjust driver's seat

The driver's seat should be adjusted for fatigue free and comfortable work. All control elements must be able to operate safely.

Longitudinal adjustment of the seat (seat pitch)

Pull up the seat longitudinal adjustment lever and adjust the seat position by pushing the seat back, releasing the lever.

Note: Make sure the seat is attached.

Spring preload adjustment

The air seat weight can be adjusted by rotating the seat front knob.

1. Increase the spring tension by turning the regulator clockwise to accommodate the heavy operator's operating weight.
2. Reduce spring tension by turning the regulator counterclockwise to accommodate the operating weight of light operators.

Use the above method to adjust the seat for good suspension comfort.

Backrest adjustment

Slightly remove the backrest and lift the seat's left joystick. Release the joystick by leaning forward or leaning back to adjust the desired sitting position. The backrest should be adjusted in such a way that the operator's back can safely operate the joystick when fully fitted.

Note:

the highest root mean square value of whole body vibration is 0.5 m/s². the uncertainty of measurement of whole body vibration is 0.1 m/s².

Safety belt

1. Fasten your seat belt.
2. Make sure your seat belt is fastened.

Note: It is forbidden to operate excavators without safety belts.

Adjust the exterior mirrors

Check the setting of the exterior mirrors to see if the line of sight reaches the best viewing position. If not, you can

adjust the rear view mirror up, down, left and right by moving the mirror shell until you ensure the best view position.

Displays and manipulates unit descriptions

The switches of the display and operation units are versatile and can also be used for menu navigation in the display. Each function is described in detail in its respective chapters.

1. Fuel supply indicator

The fuel supply indicator shows the relative amount of fuel in the tank.

2. Charge indicator light

If there is not enough voltage in the charging circuit, the charging indicator lights up.

3. Engine oil pressure indicator light

When the oil pressure is below the set value, the engine oil pressure indicator lights up.

Other devices in the driver's seat

Other devices in the driver's position are described below.

Instruction box

The instruction box is located directly in front of the console.

Gauge adjustment button

If the excavator is equipped with a gauge adjustment device, the excavator's track width is 990 mm to 1300 mm

Set the warping switch to the expansion gear, and then step on the dozer pedal, step forward to extend the track, step back to shrink the track.

Oil level indicator

The fuel indicator is on the left side of the seat, and the fuel level is determined by observing the pointer in the indicator.

Unscrew the fuel level gauge, take out the oil level gauge, prevent the fuel hopper from coming out, and then fill.

Battery disconnect switch



Using the battery disconnect switch, the main circuit can be disconnected. The battery disconnect switch is on the left side of the seat and is marked with the power off switch.

Horn switch

The horn switch is used to control the horn on and off, and plays a warning role by sounding the horn. The horn switch is located at the center button of the right operating handle.

Control stick function overview (default settings)

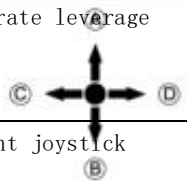
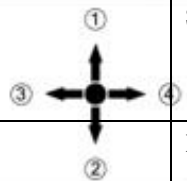
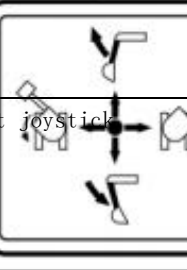
The figure combines the table to show the functions of the left and right joysticks.

Operate leverage			Sports
Right joystick		1 2 3 4	Lower the boom raise the boom fold the bucket unfold the bucket
Left joystick		A B C D	Lower the lever raise the lever rotate the upper disk left rotate the upper disk right.

Operation of the boom

If the excavator experiences an overload situation, the boom must be lowered until the load reaches the ground. To raise the boom, pull back using the right joystick. To lower the main boom, push forward using the right joystick.

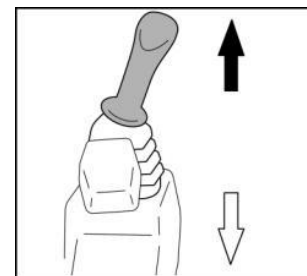

Note:

the hand-arm vibration total value is 2.5 m/s². the hand-arm vibration total value is 2.5 m/s².
The uncertainty of measurement of hand-arm vibration is 0.5/s².

Note: Observe the arm assembly while lowering to ensure there are no personnel or cargo underneath the boom.

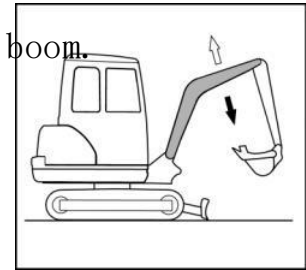

The operation of the short bar

To rotate the joystick, push the left control stick forward; to retract the joystick, pull the left control stick backward.

The joystick is moving, as shown in the figure.

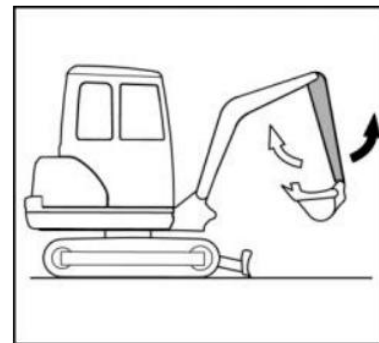

To pick up the bucket, use the right joystick and press left. To empty the bucket, use the right joystick and press right.

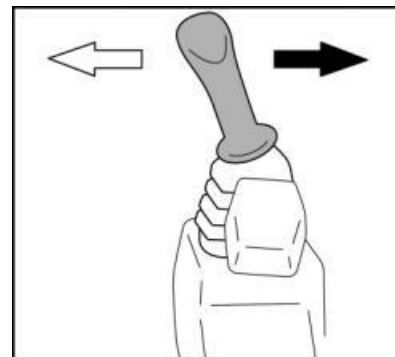

When loading into the bucket, make sure not to hit the bucket teeth against the front plate of the dozer.



The bucket is moved as shown.

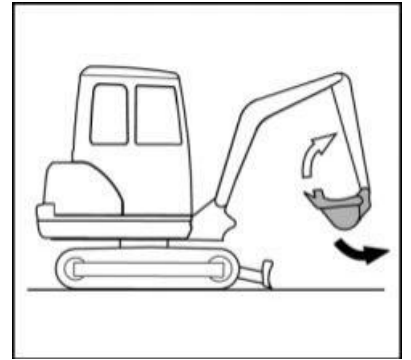

Tops (Tip-Over-Protection-Structure)

Tops is a specially designed and constructed frame that is built into (or sometimes around, in this case called an outer cage) the passenger compartment of a vehicle to protect the occupants from injury or death in an accident, especially in the event of a rollover.

The ceiling is anti-roll equipment. If the equipment is deformed, welded or twisted during daily use, please contact the factory in time for replacement. Don't take any chances with it.

Disassembly procedure

1. Bundle the lifting equipment to the four corners of the ceiling;
2. Remove the three M10 screws at the front end of the ceiling, and then remove the four M14 screws at the back side of the ceiling.
3. Lift the equipment slowly to lift the entire ceiling over the seat and console.
4. Move the ceiling to the left and then slowly place it to complete the disassembly work.

Installation procedure

1. Place the ceiling on the left side of the hydraulic excavator and bundle the lifting equipment to the four corners of the ceiling
2. Lift the equipment slowly to lift the entire ceiling over the seat and operating table
3. Move the ceiling to the right, slowly drop the upper end of the seat and operation, and tighten the mounting holes.
4. Loosen the binding point of the lifting device to complete the installation.

Safety rules for change the direction of the machine

1. Before driving, place the machine so that the sprocket (1) is behind the driver's seat.

If the sprocket (1) is in front of the cab, the machine operates the opposite of the lever

Direction movement (forward and backward walk upside down, left and right turn upside down). When in this kind of love

Special attention should be paid when operating the machine under the condition.

2. Before walking, please check that there is no one in the surrounding area and that there are no obstacles.

3. Before walking, sound your horn to warn the people in the area.

4. Only sit in the seat to operate the machine.

5. No one is allowed to ride the machine except the operator.

6. Check whether the walking alarm device works normally.

7. When the machine turns or turns, pay special attention not to touch other machines or personnel.

8. Observe the above precautions, even if the machine is equipped with a rearview mirror.

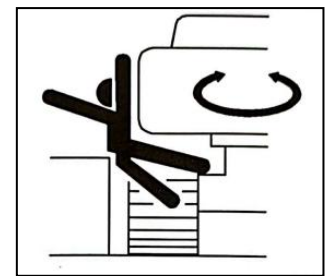

Safety rules for walking

1. When walking on a flat ground, the working device should be kept 40~50cm off the ground (16~20in).

2. When walking on a rough ground, walk at low speeds, and not suddenly

Operation steering, which poses the risk of the machine overturning. The working device would hit the ground, Take the machine off balance, or it can damage the machine or structure.

3. When walking on rough ground or on steep slopes, if the machine is equipped with automatic deceleration

Device, to turn the automatic drop switch off (cancel).

If the automatic down switch is on,

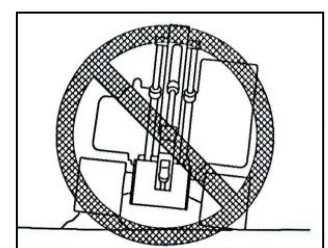
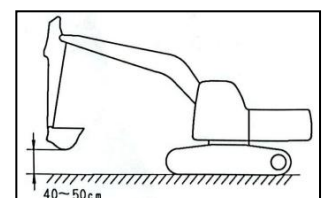

The engine speed will increase, and the walking speed will suddenly increase.

4. Avoid walking on the obstacle as much as possible, if the machine has to go up on the obstacle

Go, to keep the working device close to the ground and walk at a low speed. Don't be more violent

Walking on the side.

5. When walking or operating, always one with people, buildings, or other machines

Safe distance to avoid contact with them.

6. When passing over a bridge or a building, first check whether the structure is strong enough to support the weight of the machine.

7. When walking on the highway, first ask the relevant authorities to check and follow their instructions.

8. When operating in tunnels, under bridges, under wires, or in other places of limited height, operate slowly and take special care not to let the working device touch anything.

Walk on the slope

To prevent the machine from tipping or sliding, follow the following requirements.

1. When walking on a slope, keep the working device 20 to 30cm above the ground

(8 to 12in). In an emergency, the working device can be quickly lowered to the ground

To help to stop the machine.

2. When walking uphill, shift the cab to face uphill. instantly

When walking on the slope, turn the cab downhill.

When walking, one

Check the hardness of the ground in front of the machine.

3. When climbing a steep slope, to extend the work device ahead, to increase the balance, to make

The working unit remains 20 to 30cm from the ground (8 to 12in) and walks at a low speed.

4. On the current slope, reduce the engine speed to keep the walking lever close

"Middle" position and walked at low speed.

5. Walk on the slope straight up and down, and turn on or across the slope

It is very dangerous.

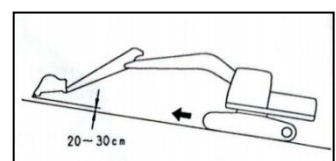
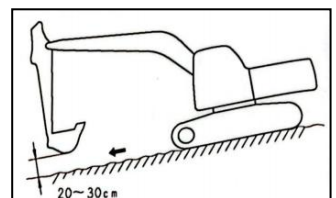
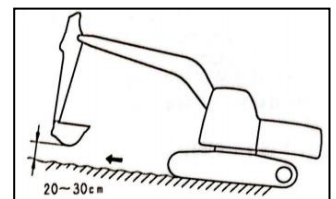

Do not turn on or cross a slope. Be sure to go down to a flat place to change it

Change the position of the machine, and then go up the slope again.

6. To walk at low speed on grass, deciduous, or wet steel plates, because even on very small slopes

In the case of 130 degrees, the machine is also in danger of slipping.

7. If the engine stalls while the machine is walking on the slope, move the control lever immediately

To the "middle", restart the engine.

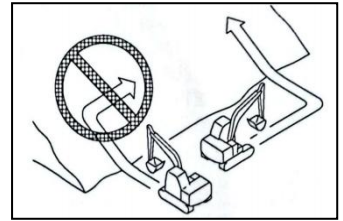

Operate on the slope

1. When working on the slope, the machine will be lost when operating the rotary or working device

To balance and the danger of tipping. This can cause serious injury or equipment damage. follow

This, when performing these operations, a flat area should be provided and be careful operate.

2. Do not turn the working device back from the uphill side to the downhill one when the bucket is full side. This operation is dangerous and can tip over the machine.

3. If the machine must be used on a slope, pile up one as much as possible

Machine-level platform (A).

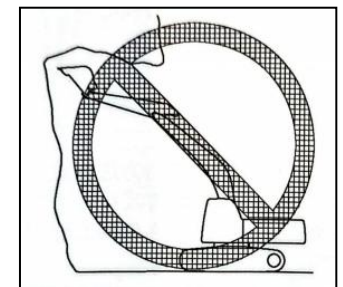
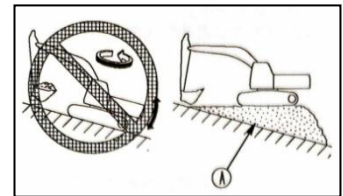

Prohibited operations

1. Do not dig up the working face below the suspended part, which will have the risk of falling rocks or, The danger of hitting the machine.

2. Don't dig too deep in the front and bottom of the machine. Otherwise, the ground below the machine may be

Will collapse to drop the machine.

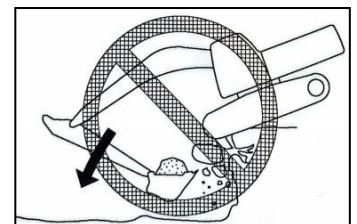

3. When excavating, adjust the track to a right Angle to the shoulder or cliff

And the sprocket is in the rear position so that the machine is easy in any case withdraw from.

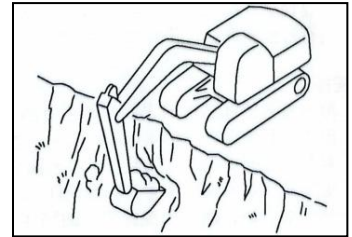

4. Do not dismantle the operation under the machine, which will make the machine unstable and have The danger of tilting.

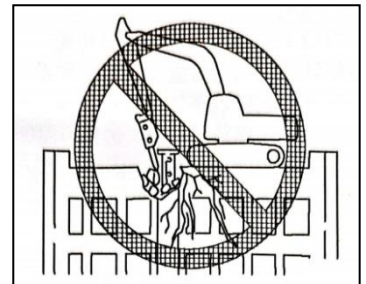

5. When working in the upper part of a building or other structure, stop before starting the work

Check the strength of the structure. There is a building to collapse and cause serious injury or damage danger.

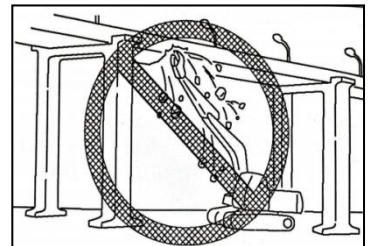

6. When dismantling, do not remove overhead. This will be broken

The danger of falling broken parts or building collapse and causing serious injury or damage

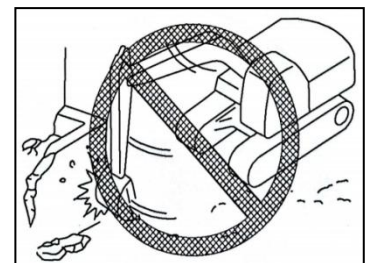

7. Do not use the impact of the working device to crushing. There will be broken material

The risk of causing personnel injury or damage to the work device,

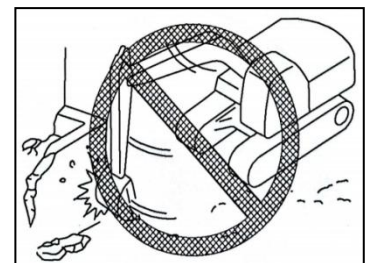

8. In general, a working device is more likely to occur on the side than when it is in the front or rear tip-over.

9. There is a risk of losing balance and tipping when using crushing hammers or other heavy working devices. When operating on flat ground and on slopes.

Do not suddenly drop, turn around, or stop the working device.

Do not suddenly extend or withdraw the arm cylinder. This poses the risk of the machine tipping over due to the impact force.

10. Do not cause the bucket to pass over the heads of other workers or above the operator seat of the dump truck and other transport

equipment. Because the load is likely to fall down, the bucket may hit the dump truck, causing serious injury or damage.

Snow day operation

1. Snow-covered or frozen surface is very slippery. When walking or operating the machine, be particularly careful not to suddenly operate the lever. Even small slopes can skid the machine, so special attention should be taken when working on the slopes.
2. For the frozen ground, the ground becomes soft when the temperature rises, which causes the machine to roll over.
3. If the machine enters deep snow, it is a danger of falling over or buried in the snow. Be careful not to leave the shoulder or fall in the snow.
4. When clearing the snow, the objects on the shoulder and near the road are buried in the snow and cannot be seen in the snow, so there is a danger of the machine tipping over or bumping into the buried object, so we must be careful to operate it.

Parking machine

1. Park the machine on a solid and flat ground.
2. Choose a place where there is no danger of rockfall or landslides or if there is no danger of flooding the low ground.
3. Lower the working device to the ground.
4. When leaving the machine, pull the operation lock to the locked position, and then close the engine.
5. To prevent unauthorized personnel from moving the machine, close the cab door and lock all the devices with a key. Take off the key, take it with you, and put it in a specified place.
6. If the machine must be parked on the slope, follow the following regulations.
7. Adjust the bucket to the downhill side and insert the bucket into the ground.
8. Place pads under the tracks to prevent the machine from moving.

transport

For transport, the machine can be divided into several parts. Thus, when transporting the machine,

Please contact the factory for this work.

Installation and unloading of machines

When loading and unloading the machine, the wrong operation will have the risk of frequent machine turning or falling,

Special care must therefore be taken. Be sure to do the following.

1. It can only be installed and unloaded on the hard, flat ground.

From the edge of the road

Or cliff maintain a safe distance

2. Do not install or unload the machine with the working equipment.

There is a danger that the machine may fall or roll over.

3. Use a springboard of sufficient strength to ensure that the springboard width, length and thickness to provide safe handling slope.

4. Ensure that the springboard surface is clean and free of grease, oil, ice and loose material. Remove the dirt from the machine tracks. Especially in rainy days, because the surface of the springboard is slippery, you should be extra careful.

5. Close the automatic deceleration switch (the automatic deceleration function is cancelled). Run the engine at a low speed and walk slowly.

When on the springboard, do not operate any lever other than the walking lever.

6. Do not correct the direction on the springboard. If necessary, drive out of the springboard, correct the direction, and then drive back on the springboard.

At the connection between the springboard and the track or trailer, the center of gravity of the machine will suddenly change and risk the machine losing its balance. Lead through the connection slowly.

7. When loaded or unloaded on the subgrade or platform, ensure that the subgrade or platform has the appropriate width, strength and slope.

When turning the superstructure on the trailer, the trailer is unstable, thus withdrawing the working device and turning slowly.

8. For the machine equipped with the cab, load the machine and lock the door well. If this is not done, the machine door will suddenly open during transport.

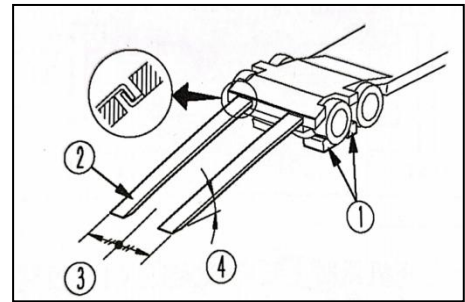

(1) pad (2) springboard (3) the center line of the trailer (4) set the Angle of the springboard

Transportation machine

When transporting the machine on a trailer, do the following.

1. The weight, transport height and total length of the machine vary according to the working device, so be sure to confirm the size.
2. When passing a bridge or building on private land, it is first checked whether its structure is sufficient to support the weight of the machine. When walking on the highway, the relevant management agencies shall first check and follow their instructions.
3. The transportation machine should be hoisted and bundled transported according to the position points in the following picture.

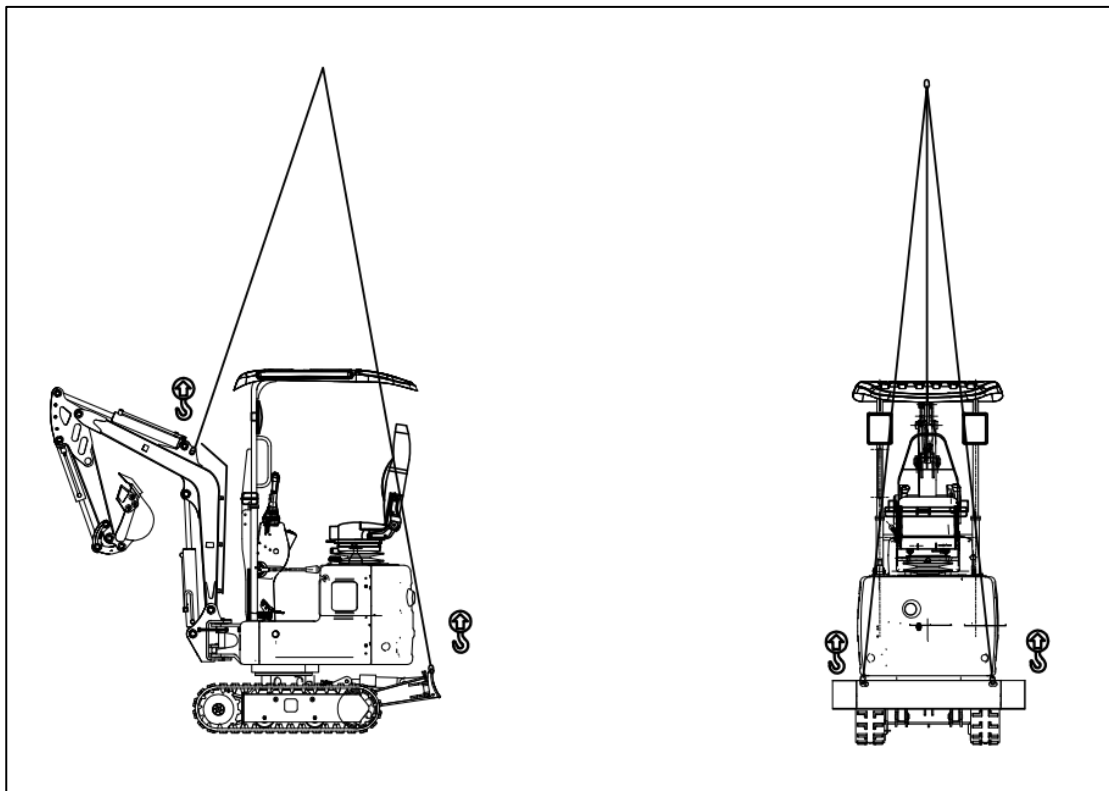

Lift the object with a bucket

Generally, the operation of lifting objects with machines of standard specifications is prohibited.

Lift ist with hook bucket

Usually, lifting operations are prohibited. However, if the operation meets the specified conditions and only the specified conditions are met, the hook bucket is permitted.

Improve the safety rules for objects

1. Do not lift operations on slopes, soft ground, or other places where machines are unstable.
2. Use a wire rope that meets the specified standards. Do not exceed the specified lifting load.
3. If the load hits people or buildings, it is very dangerous. Before the machine turns or turns, check the surrounding area for safety.
4. Do not suddenly start, turn, or stop the machine, so that the increased load is in danger of swinging.
5. Do not pull the load sideways or toward the machine.
6. Do not lift the operator seat when the load is lifted.

For the details of the maximum allowable lifting load of this machine, see the figure below.

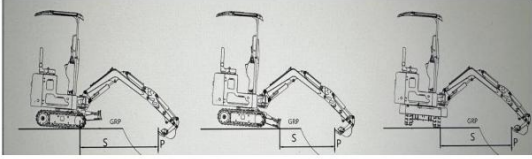
1. Calculation of stability			
			
Working condition	Tipping force P (KN)	Moment arm S (m)	Tippingmoment (KN. m)
Lengthwise (Track support)	1.27	1.92	2.44
Lengthwise (Bulldozer support)	3.53	1.41	4.96
Horizontal	1.08	1.87	2.30

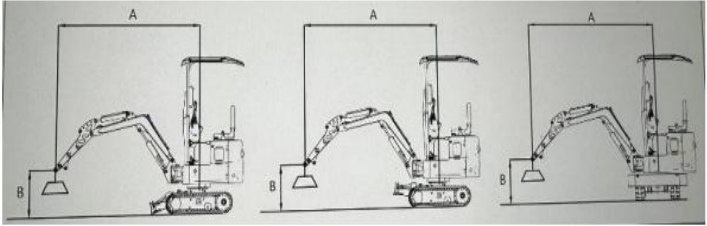
2. Lift capacity ratings	
	
A: Load radius	Conditions of operation
B: Load point height	1480mm BOOM
Cs: Rated loads over side	rack plate is 180mm wide
(Unit: kg)	

Load point height (Unit: m)	Load radius A (Static-bulldozer support)								
	1.5		2		2.5		Max		
	Cf	Cs	Cf	Cs	Cf	Cs	Cf	Cs	A(mm)
1	460	240	350	160	300	120	280	110	2650
0.5	570	260	450	180	320	130	300	110	2630
0 (Grade)	660	280	480	200	340	137	300	105	2600
-1	/	285	410	205	/	/	310	117	2516
-1.1	680	320	/	/	/	/	/	/	/

Load point height (Unit: m)	Load radius A (Dynamic-no bulldozers)								
	1.5		2		2.5		Max		
	Cf	Cs	Cf	Cs	Cf	Cs	Cf	Cs	A (mm)
1	300	240	220	160	150	120	130	110	2650
0.5 (Grade)	320	260	280	180	170	130	120	110	2630
0	330	280	300	200	180	137	130	105	2600
-1	/	285	300	205	/	/	125	117	2516
-1.1	680	320	/	/	/	/	/	/	/

Chapter 4: Basic parameters of the excavator

4.1 General diagram

Name of Main structural component (GG 800 N)

grade	name	
1	commutating tooth	
2	dens lateralis	
3	bucket	
4	connecting rod	
5	rocking bar	
6	Shovel bucket cylinder	
7	dipper	

8	The bucket pole cylinder	
9	swing arm	
10	Move the arm cylinder	
11	dozer blade	
12	Guide the wheel	
13	thrust wheel	
14	driving wheel	
15	track	
16	Rear cover	
17	Left shield	
18	seat	
19	handrail	
20	Mechanical throttle	
21	Headlight switch	
22	schedule	
23	key hole	
24	Power supply main switch	
25	Diesel level table	

4.2 Hinge-connected pin of the machine working device

Position indication of machine worker pin shaft (GG 800N)



order number	Connect pin shaft
1	The boom / upper frame connects to the pin axle
2	Arm cylinder / upper frame connecting pin axle
3	The boom cylinder / boom connects to the pin shaft
4	Connect the bucket cylinder / boom to the pin shaft
5	Connect boom / bucket to the pin shaft
6	Bucper cylinder / bucket connecting pin shaft
7	The bucket cylinder / rod connects the pin shaft
8	Pole cylinder / rocker / link connecting pin shaft
9	Connecting rod / bucket connecting the pin shaft
10	Bucper / rocker connecting pin shaft
11	Bucbar / bucket connecting pin shaft
12	Fixed pin shaft and connecting pin shaft for bulldozers / unloading rack

4.3 Main dimensions and specifications

Direction of main excavation range of excavator (GG 800N)

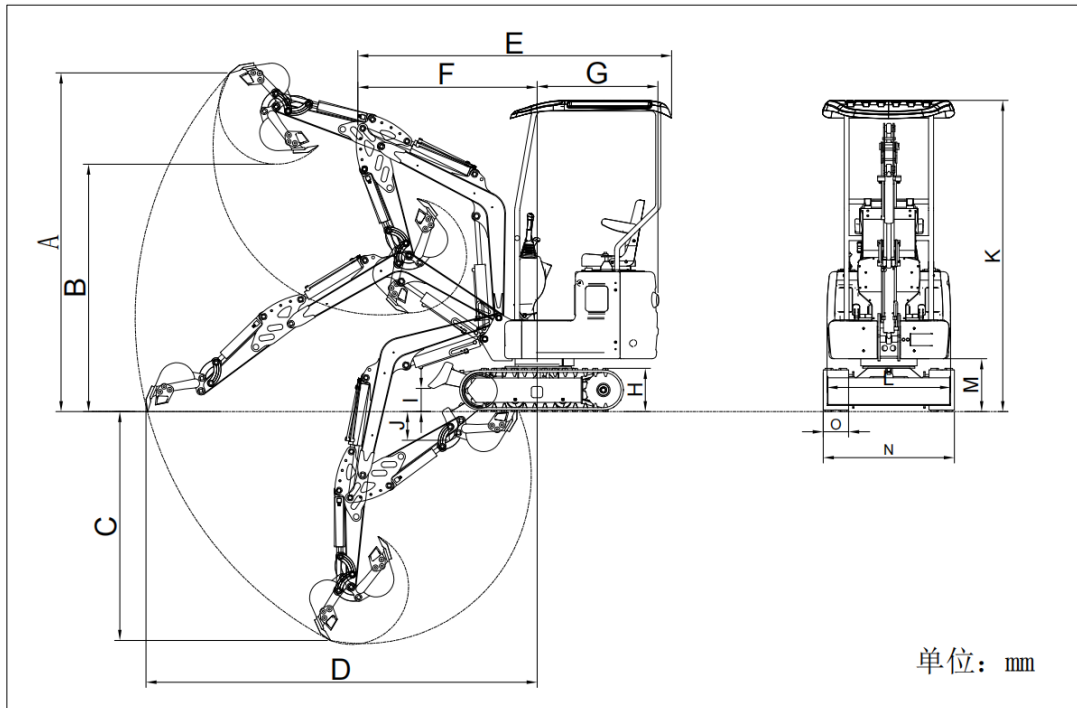

working range		unit:mm
		GG 800 N
A	Maximum ground excavation height	2407
B	Maximum unloading depth	1758
C	Maximum mining depth	1625
D	Maximum range of ground activity	2781
E	Transportation length	2230
F	radius of gyration	1275
G	Minimum tail radius of rotation	859

H	Track height	308
I	Maximum lifting height	165
J	Tupush maximum subsidence height	203
K	The car body is always high	2211
L	The car body is always wide	932
M	The height of the car body	376
N	Push the width of the shovel	878
O	Track width	180

4.4 Hydraulic schematic diagram and details

Hydraulic schematic diagram

As an important part of hydraulic system design, its function is to clearly show the working principle, structure and control mode of hydraulic system. According to the hydraulic schematic diagram of the machine hydraulic oil road, more can be used for the problem of hydraulic pipeline.

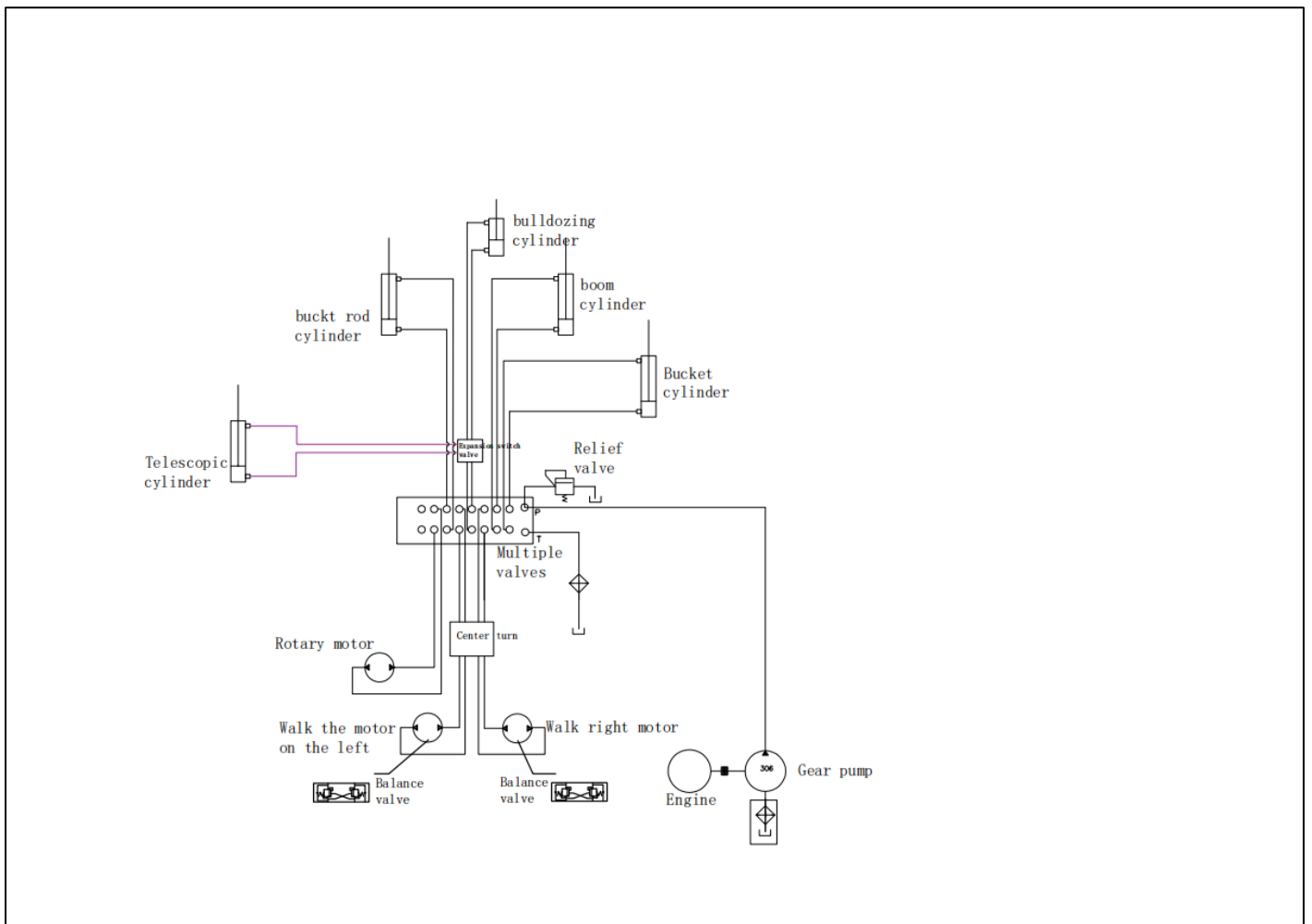

Hydraulic parts details

For a comprehensive understanding of each hydraulic component in the hydraulic pipeline, the manufacturer and model parameters of the hydraulic components can be used for the damage and replacement of the components.

Hydraulic component details				
	Component name	Sub-assembly model	Brand	Typical parameter
1	Tighten the nut	CBT-E306R2HR1	Shengjie	Specification: 306
2	Gear pump	LP0101030017	tengfei	Rated pressure:
3	Multi-way valve	JT2169	jitai	18 MPa / Rated flow: 80 L/min
4	Boom cylinder	JT2172	jitai	Rated pressure: 21 MPa
5	Bucket cylinder	JT2170	jitai	Rated pressure: 21 MPa
6	Stick (arm) cylinder	JT2520	jitai	Rated pressure: 21 MPa
7	Tilt cylinder	JT2619	jitai	Rated pressure: 21 MPa
8	Telescopic cylinder	YSV23-12	yikaidei	Rated pressure: 21 MPa
9	Telescopic solenoid valve	BM2-315	deshi dun	Rated pressure: 21 MPa
10	Swing motor	BM6-315	zhenjiangdali	Rated pressure: 21 MPa / Connection type: spline
11	Travel motor	FST20-31A-0000	yikaide	Rated pressure: 21 MPa / Displacement: 315

4.5 Electrical schematic diagram and details

Electrical schematic diagram

As an important part of the circuit design, the electrical schematic diagram is used to clearly show the working principle, structure and control mode of the circuit. According to the electrical schematic diagram of the machine electrical layout for a comprehensive understanding, but also can be used for electrical problem troubleshooting.

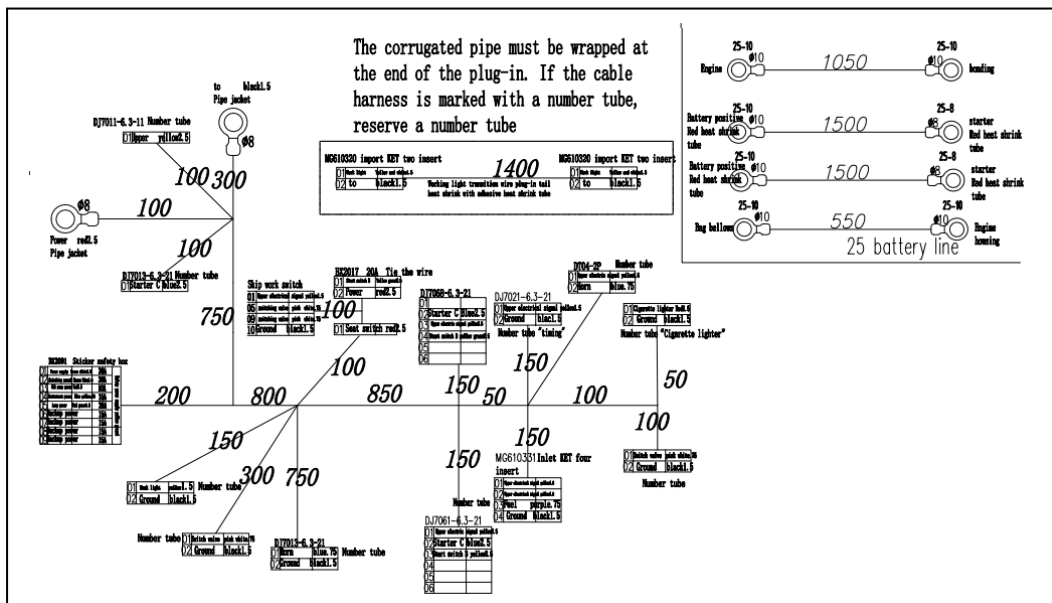
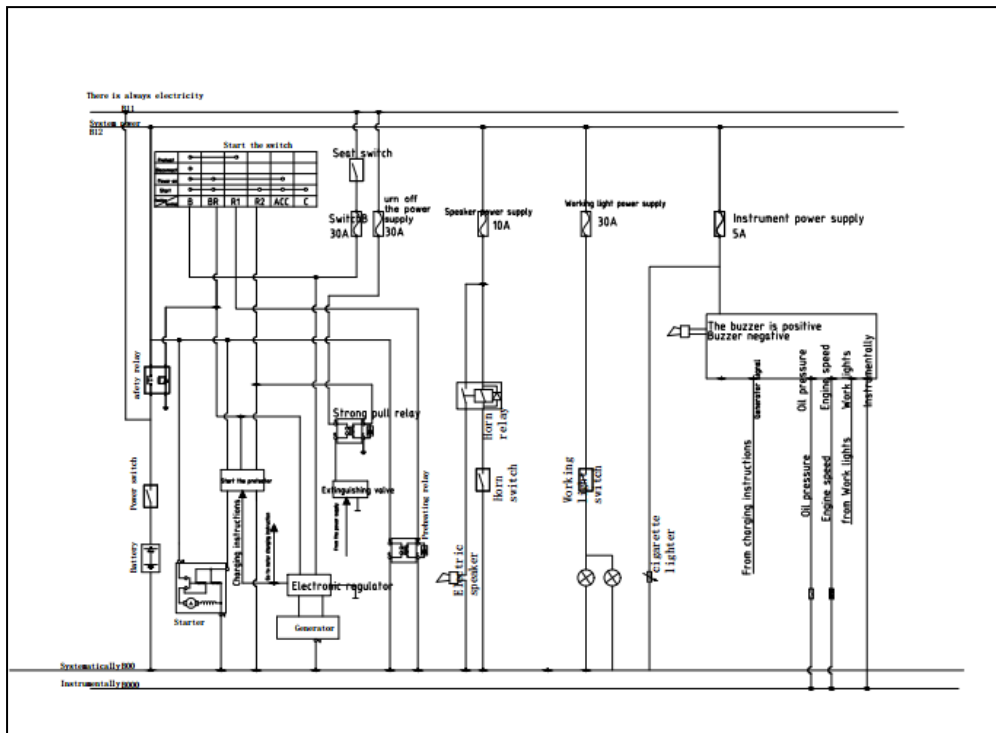

Electrical parts details

For a comprehensive understanding of the various electrical components in the whole circuit, the manufacturer and model parameters of the electrical components can be used for the damage and replacement of the components.

No	Component name	Model	Brand	Parameters
1	Battery	LP0106010001	baosheng	Voltage: 12V / Capacity: 454/h
2	Power switch	LP0106040007	tianxing	Voltage: 12V
3	Electric horn	12V tone	weixin	Voltage: 12V / Power: 2W
4	Work light	LiuZhu	yangguang	Voltage: 12V / Power: 50W
5	Distortion switch	JK993	deli	Voltage: 12V
6	Electronic oil pump	LP0111020143	sanma	Voltage: 12V / Flow rate: 100 L/h
7	Instrument power supply (5A/10A/30A)	GM41H	deli	Voltage: 12V
8	Single fuse	BX2017	deli	Current: 5A / 10A / 30A
9	Electronic lighter	KWG-Y6	kaiwei	Voltage: 12V / Power: 120W
10	Horn relay	TVTE-2914	zhongzhi	Voltage: 12V
11	Safety relay	TVTE-3514	zhongzhi	Voltage: 12V
12	Start protector	TVTE-3574	zhongzhi	Voltage: 12V
13	Fire extinguishing valve	TVTE-4475	zhongzhi	Voltage: 12V
14	Heavy-duty pull-in relay	TVTE-3579	zhongzhi	Voltage: 12V
15	Preheating relay	TVTE-3571	zhongzhi	Voltage: 12V
16	Seat switch	z-15GW	tiancheng	Voltage: 12V
17	Start switch	YNDHS 001	zhongzhi	Voltage: 12V

Chapter 5: Common faults and solutions

5.1 Common faults and solutions of excavator

Common fault	failure cause	Rx
The machine is weak and slow to move	The overflow valve is blocked or overloose	Remove the cleaning or tighten the overflow valve
	Pump damage	Replace the hydraulic pump
	The oil pump inlet pipe is blocked	Clean up or replace the oil intake pipe
	engine failure	Contact the manufacturer to repair the engine
The machine has no action	Pump damage	Replace the hydraulic pump
	Connecker spline damaged	Replace the coupling spline
	The fuselage tilt bias the hydraulic oil To the side	Add the hydraulic oil or set the machine to a level
The machine cannot rotate	The rotary motor gear falls off	Install the swing gear in place
	The rotary motor is damaged	Replace the rotary motor
The engine emits a weak blue smoke	Excessive oil filling	Adjust the oil quantity according to the upper and lower limit of the oil gauge
	engine failure	Contact the manufacturer to repair the engine
The engine emits weak black smoke	Air filter blocked	Clean up or replace the air cleaner
	engine failure	Contact the manufacturer to repair the engine
The engine is smoking white	Mix the water in the diesel oil	Release the oil and regain
Engine holding car	The overflow valve is stuck	Remove the overflow valve and install gasoline gasoline and with gasoline

	The overflow valve is adjusted too tight	Tune loose overflow valve
The engine does not catch fire	Battery loss voltage	Charge or catch fire with an external battery
	Diesel oil is dry to fuel the pipe There is air in the road	Unplug the diesel pipe on the engine to drain air, install or press the hand oil pump to drain air
	Diesel freeze	Choose the appropriate diesel grade according to the local temperature
	engine failure	Contact the manufacturer to repair the engine
	The nozzle is blocked	Replace the nozzle
	Air filter plug	Replace the air filter element
	High pressure oil pump damage	Replace the high pressure oil pump
	Fuse broken	Check and replace the fuse
	Electronic oil pump failure	Replace the electronic oil pump
	High pressure oil pump damage	Replace the high pressure oil pump
	The low temperature causes the engine oil to be too thick	Change the appropriate grade number of the oil
The engine throttle is both big and small	Diesel tubing folding, causing oil supply Not smooth	Check the diesel oil pipe and adjust the direction to ensure the smooth oil supply
The throttle continues to increase	Engine throttle holder is locked	Release the engine throttle holder
The throttle cannot be increased	The throttle pull cable is loose	Tighten the throttle pull cable trap

Common fault	failure cause	Rx
Headlights are not on, the code meter or display does not work	Line plugs fall off	Check whether the line plug is falling off or is loose
	Parts damage	Replace parts

The battery is not charged	The generator line breaks	Check the engine wiring and reconnect it
	Fuse damage	Change the fuse
	The regulator is damaged	Replace the regulator
	Battery damage	Replace the battery
The crawler falls off	Mechanical tensioning is slack	Support the machine, put the crawler into the tightening wheel and start the machine, use the rotating force of the driving wheel, and adjust the mechanical tension device until the crawler rises
Engine high temperature	Lack of antifreeze	Add antifreeze
	The cooling sink is blocked	Clean the cooling hole of the water tank
	Damage of thermostat	Replace the thermostat
	Plateau climate impact	Replace the high-pressure water tank cover
	engine failure	Contact the manufacturer to repair the engine
Oil pressure alarm	Lack of oil	Add oil
	engine overheat	Check the coolant
	Sensor damage	Replace the sensor
	line fault	Check the line
An excavator oil cylinder cannot move do	Break the lever ball shaft or base	Replace the ball shaft or base, and refer to Section 9.2 for the disassembly method
The operating lever cannot be returned or pushed back put sth. in place	Multi-channel valve stem return spring is fixed The setting screw is either becoming loose or falling off	Reinstall the return spring or tighten the return spring fixing screws, see Section 9.3 for the disassembly method
	The core card is dead	Refer to sections 9.2 and 9.3, remove the spool and reinstall

5.2 Clean the relief valve (safety valve) and adjust the system pressure

As one of the core components of the hydraulic system, the overflow valve plays a decisive role in the system pressure. If the overflow valve is too loose or stuck, it will lead to the machine is obviously weak, slow moving, walking, turning and climbing, and the crushing hammer does not hit. The adjustment will lead to the car when the machine works extremely fast, and the oil temperature rises too fast.

Cleaning method of the overflow valve

Remove the overflow valve after opening the main valve cover (shown below)

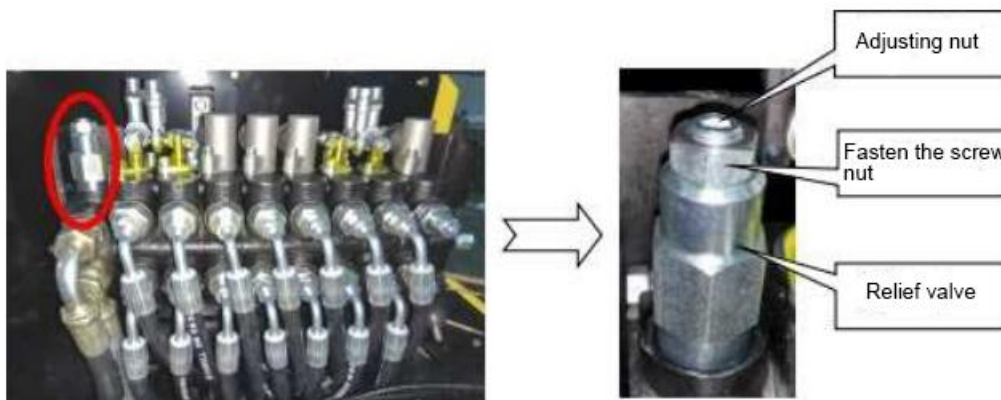

Remove the entire overflow valve, record the position of the control screw opposite to the lock nut, then release the lock nut and remove the control screw with a 6mm inner hexagon wrench.

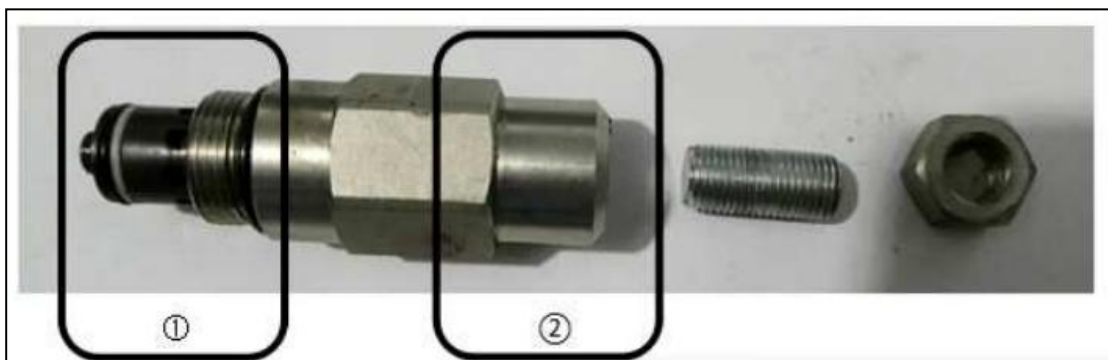

1. Soak frame 1 in gasoline back and forth several times.
2. Press box 2 side down and strike gently.
3. Repeat the 1. 2 action until the overflow valve can be heard when the internal component snap impact sound is shaken horizontally, and the overflow valve is cleared.
4. Install the adjustment screws and lock nut back to the original state.
5. Install the overflow valve into the valve body and tighten it.
6. Start the machine, adjust the system pressure: engine throttle to 80% -90%, the valve stem will be the large arm cylinder stretch to the longest, hold the stem about 5 seconds, observe the engine deceleration or stall, if there is no obvious change, continue to adjust the nut clockwise half circle, repeat the above operation, until the engine load significantly increased, but not stall (if the engine deceleration and black smoke, and 5 seconds, the pressure adjustment is too high, need to counterclockwise screw, reduce the system pressure). After the adjustment, tighten the lock nut, install and reset the shield valve stem, clean the overflow valve and adjust the system pressure.

5.4 Installation of detached tracks

First start the machine, will fall off the fuselage lift, take off the rubber tracks unloading, and then put the crawler into the guide wheel (pay attention to the track direction don't mistake), pull the other end of the crawler, and start the machine and operating the stem for the drive wheel slowly down to the drive wheel at the same time, using the machine driving force and crowbar auxiliary, until the crawler completely loaded.

Then, by adjusting the mechanical tensioning device and tightening the track, special attention should be paid to safety during these series of operations. The improper operation will lead to serious safety accidents (such as track involvement, crowbar swinging or flying out, etc.). In uncertain circumstances, please contact the manufacturer for guidance.

5.5 The engine cannot catch fire when the diesel runs out

Once the fuel runs out and fails to catch fire, first replenish the fuel and then drain the air from the line. GG800N excavator adopts 192 engine, which has no manual oil pump, so it needs to remove the maintenance cover in front of the engine, and then remove the engine oil intake pipe. When the pipeline has oil and no bubbles,

the pipeline should be installed on the engine and tightened, and the fire can be started for two or three times.

Chapter 6 Maintenance and Maintenance

6.1 Notes for maintenance

engine maintenance

As the main power system of the excavator, the engine needs to be maintained in accordance with the "engine operation manual" carried by the vehicle. The maintenance in strict accordance with the provisions in the engine operation manual can effectively improve the engine life and reduce the occurrence of faults.

The main maintenance content mainly includes the following parts:

1. Engine run-in period care.
2. Oil replacement cycle, and supplement. (The oil will be consumed slowly with the use of the machine, so it is necessary to check the oil volume regularly, it is not a filling until the next replacement, the need to timely supplement when the oil is insufficient, otherwise it will cause serious consequences such as pulling cylinder, the engine damage caused by the lack of oil manufacturer will not warranty)
3. Replacement cycle of oil filter and diesel filter element
4. Air filter element replacement cycle

Mark the "Do not operate" warning message

When inspecting or maintaining the machine, an unauthorized person starts the engine or touches the control handle.

Before maintenance, please turn off the engine, remove the key and take it with you.

Mark the "Do not operate" warning message in prominent places such as the starting switch or control lever.

Use the right tool

Do not use damaged or poorly performing tools or designs for other purposes

Tool for use. Use tools suitable for related jobs.

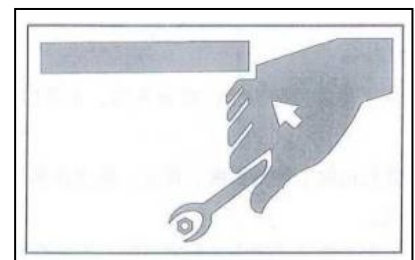

Replace the safety-key components regularly

1. To ensure that the machine can be used safely for a longer time, regularly refueling and check and maintain. To improve safety, please replace safety key components such as hoses and safety belts regularly.
2. "Safety-critical components replaced regularly" means the parts that age, wear and function degrade after reuse, and the performance of such components will change over time. These characteristics of such parts can cause serious mechanical damage or personal injury, and it is difficult to judge the remaining service life only based on visual inspection or operation feel.
3. If there is any damage to the visual appearance, please replace the "safety key parts replaced regularly", even if the specified replacement interval has not been reached.
4. Change the fuel hose regularly. Fuel hoses wear over time, even without any wear symptoms.
5. Replace with any wear symptoms, regardless of the replacement schedule.
6. To use the machine safely, please check and maintain it regularly. The following safety-critical components must be replaced regularly to improve safety. Damage to these parts can cause serious injury or a fire.

Safety Critical Parts List

Body	Safety-critical parts that are regularly replaced		Replacement time
Fuel system	Fuel pipe		Every 2 years
	Packing on the fuel tank cap		
Hydraulic system	Main engine	Hydraulic pipe (pump outlet)	Every 2 years
		Hydraulic pipe (pump suction port)	
		Hydraulic pipe (swing motor)	
		Hydraulic pipe (travel motor)	
	Working equipment	Hydraulic pipe (boom cylinder pipe)	
		Hydraulic pipe (stick cylinder pipe)	
		Hydraulic pipe (bucket cylinder pipe)	
		Hydraulic pipe (pipeline of yaw cylinder)	
		Hydraulic pipe (bulldozer cylinder pipeline)	
		Hydraulic pipe (pilot valve)	
Hydraulic pipe (auxiliary pipe)			

6.2 Fuel oil recommendation

Diesel fuel shall meet the following standards and this table lists several current fuel specifications in the world.

Fuel specification	position	Diesel specifications	position
--------------------	----------	-----------------------	----------

GB252	China	Of either BS2869-A1 or A2	Britain
ASTM D975 Number: 1-D, S15	America Canada	ISO 8217DMX	international
biodiesel The biodiesel mixture was B5 ASTM D6751, D7467			
EN590:96	EU	Grade JIS K2204 2	Japan
biodiesel The biodiesel mixture is the B5 EN14214, EN590			

1. To maintain the engine performance and service life, always use clean, high-quality fuel.
To prevent freezing in cold weather, choose the diesel oil that still applies when the actual temperature is at least 12°C lower than the expected minimum outdoor temperature.
2. Please use diesel oil with cetane value of 45 or above. When used in high cold or high altitude areas, fuel with higher cetane value is required.
3. The sulfur content and volume ratio is less than 0.05~0.1 or 15% fuel. (Ultra-low sulfur fuel should be used in the United States or Canada) Using high sulfur fuel may cause sulfuric acid corrosion in the engine cylinder.

The use of kerosene is prohibited. Do not mix kerosene, used engine lubricants or residual fuel with diesel oil.

Poor quality fuel can reduce engine performance or cause engine damage. Fuel oil additives are not recommended. Some fuel additives can cause a degradation in engine performance. Metal content, such as zinc, sodium, silicon, and aluminum, must be limited to one part per million quality (1 mass ppm) or less.

Safety measures when using biodiesel, the engine manufacturer's warranty is not valid for machines that do not meet standards or deteriorated biodiesel.

6.3 Indication of the machine lubrication parts

Lubrication area diagram

The details of the 18 refueling ports of the GG800N model are shown as follows:

Grease mouth position	quantity
(1) Connect the left and right legs of the push shovel with the lower plate	Two grease mouths
There is no connection between the rod end and the bulldozer of the bulldozer oil cylinder, and the connection between the rod end and the lower plate of the bulldozer oil cylinder	Two grease mouths
(2) Connection of the boom bracket and the boom	A grease mouth
(3) Arm oil cylinder	Two grease mouths
(4) Pole oil cylinder	Two grease mouths
(5) The connection of the boom and the bucket rod	A grease mouth
(6) Bucket oil cylinder	Two grease mouths
(7) Joystick, connecting rod	Four grease mouths
(8) Gear lubrication of rotary motor and internal ball lubrication of rotary support	Two grease mouths

Location diagram of the total number of 18 refueling ports of the GG800N model:



Users must add sufficient grease to the above refueling points every 8 hours. ※

6.4 Maintenance catalogue

Schedule of the excavator maintenance catalogue:

Excavator maintenance catalog

Filter element name	First time		conventional		model	Remark
	time	Maintenance method	time	Maintenance method		
Oil filter	50h	replace	200h	replace	/	
Air filter	50h	Clean up	200h	replace	/	For severe working conditions, the cleaning and replacement cycle will be shortened (air blowing, not washing)
Diesel filter	50h	replace	200h	replace	/	
Pilot filter	500h	replace	1000h	replace	/	
Hydraulic suction filter	300h	replace	600h	replace	/	
Hydraulic oil return filter	300h	replace	300h	replace	/	



Oil product maintenance schedule:

Oil name	First time		conventional		model	Remark
	time	Maintenance method	time	Maintenance method		
Engine oil	50h	replace	200H	replace	CD 15W-40 (PC10 model) CF-4 15W-40 (other model)	Use the appropriate oil model according to the local temperature
antifreeze	every day	Check/Supplement	One year	replace	No. 40 glycol type engine coolant	Can not be mixed with water, can not be replaced with water (use the appropriate antifreeze model according to the local temperature)
diesel fuel	every day	Check/Supplement	/	/	/	Use diesel from regular gas stations. Inferior diesel will cause damage to fuel pumps, fuel injectors and other components (use appropriate diesel grades according to local temperature)
Hydraulic oil	300h	replace	600h	replace	46#Anti-wear hydraulic oil	
Travel motor gear oil	50h	replace	500h	replace	L-CKD 220	
butter	New machines	Raise	8h	add	/	
Water tank radiator	50h	Clean up	50h	Clean up	/	Air blowing or high-pressure water flushing
Hydraulic oil radiator	50h	Clean up	50h	Clean up	/	Air blowing or high-pressure water flushing

Inspection list of important parts:

Important inspection site	time	Maintenance method	time	Maintenance method	Remark
Rotary motor fixed screw	30H	check	30H	check	If it is loose, please tighten it immediately
Slewing support fixed screw	30H	check	30H	check	If it is loose, please tighten it immediately
Engine fixed screw	30H	check	30H	check	If it is loose, please tighten it immediately
Track tensioner	Before work	check	Before work	check	If the track becomes loose, please add butter immediately
<p>Notice: 1. Please follow the maintenance cycle, regular maintenance, the manufacturer does not provide three guarantees for equipment failures caused by untimely maintenance or non-maintenance</p> <p>2. Please use genuine parts for maintenance. Inferior parts or oil may cause rapid wear or serious failure of the equipment</p> <p>3. Failure to check the slewing motor fixing screws, slewing support fixing screws, and engine fixing screws regularly may result in slewing motor gear <u>toothing</u>, flange damage, slewing support <u>toothing</u>, engine wind ring damage, water tank leakage and other accidents. The manufacturer does not provide three guarantees for damaged parts.</p>					

6.5 List of filter element models

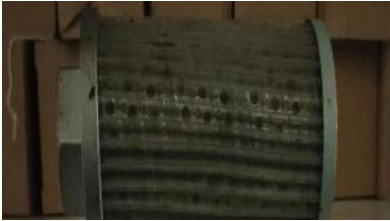
	GG800N model
Air filter / model	
Chai filter / model	 /CX0708
Machine filter / model	 /JX0810Y
Oil- absorption filter element / model number	

6.6 Change the engine oil

Notes for oil change

1. The oil change must be carried out in the heat engine condition.
2. Do not start during the process of oil change and before the new oil is added.
3. The oil filling amount is close to the upper limit of the oil ruler but not exceeding the upper limit.
4. The engine oil filter element must be replaced while changing the engine oil.

Oil change method of GG800N model:

As shown in the figure below, unscrew the oil outlet screw, drain the oil, and catch it with a container. Unscrew the refueling cap, add new oil to the engine, and tighten the refueling cap after refueling.

6.7 Replacing the method of the filter element

As shown in the figure above, if the core is replaced, you need to open the rear cover of the excavator first, and all the filter elements can be seen after opening it. First, remove the oil pipe and joint on the filter element with a wrench, and then remove the filter element for replacement.

